

WINDOWSILLS INSTALLATION INSTRUCTIONS

INSTRUCTION PURPOSE

This document provides instructions on how to mount laminated interior windowsills, produced in postforming technology, and seal the area under a windowsill in layered brick walls. The instruction is appropriate for housing and industrial building, for dry, ventilated areas.

AREAS OF USE / APPLICATION

Due to their modern design and functionality windowsills are used only for interior applications at homes, offices, shops etc.

STORAGE

Horizontal, even storage in closed, dry areas [approx. 18-22°C, and 50 to 60% relative humidity] to exclude warping or dimensional changes due to climatic conditions. Vertical storage is not recommended. Windowsills should be handled and transported with due care.

PROCESSING

Lamintex windowsills can be processed with conventional woodworking machines. For best quality/results of windowsills, use of cutting/saw device with milling cutter is needed.

CARE AND CLEANING RECOMMENDATIONS

Lamintex windowsills are hygienic and easy to clean, for daily use can be cleaned with a damp cloth. Stains can be cleaned with all domestic cleaning agents. Stubborn stains can be cleaned with acetone, vinegar concentrate or nail polish remover. Those agents should be used only in polluted areas and for a short period of time. Do not use scouring agents.

MOUNTING INSTRUCTIONS

1. Cut a windowsill to required size by using below type of saw.

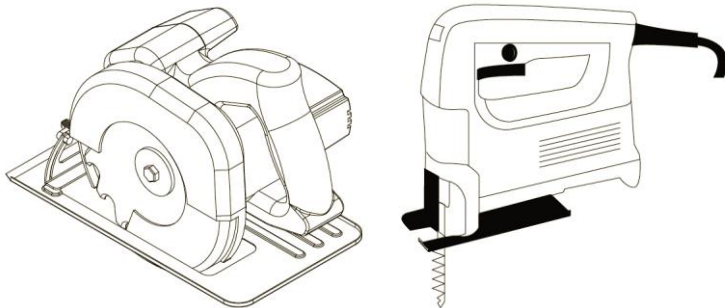

** Usage a protective tools is necessary*

2. Protect side edges from moisture (by gluing decorative laminate strips (see following steps on *drawing a*) or other edges with moisture-resistant adhesive or plastic cover cap (*drawing b*)).

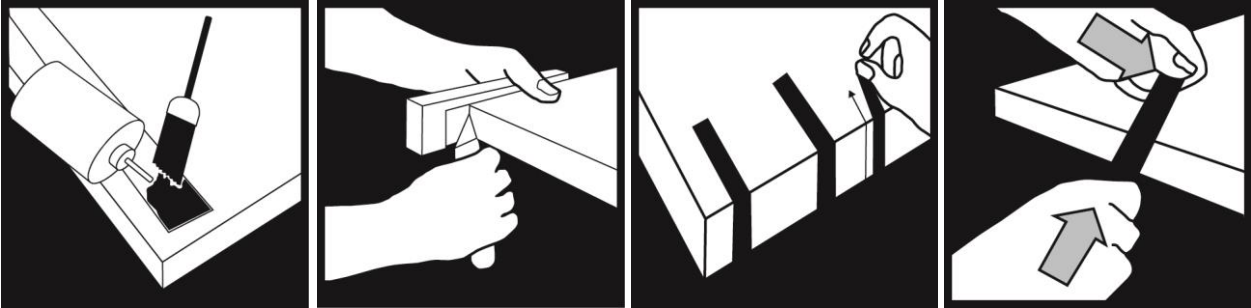

a)

3. If laminate is not protected by protective foil, it should be secured by e.g. masking tape to avoid scratching the decorative surface during installation. Part of a windowsill protruding over a wall should be protected from fouling on the reverse side as well.
4. Attach the plastic caps to the sides of the windowsill and then set a windowsill in a required position, wedge and support so as it will not change its position under the influence of PU low expanding foam.
5. Fill with PU low expansion foam to infill cavities area under a windowsill as shown below drawing

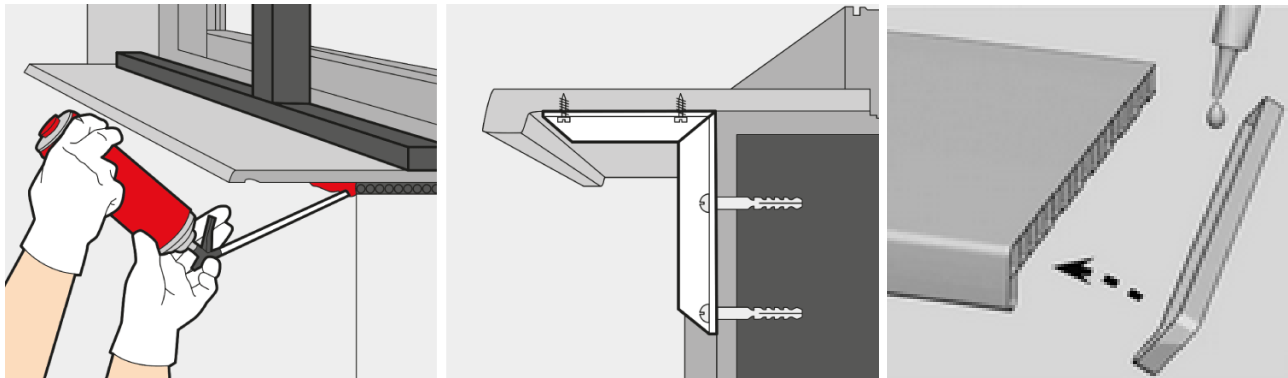

**Use additional mounting bracket if the board extends more than 100 mm from the wall.
This will provide sufficient stability.*

6. Wait 24 hours until the foam will have appropriate resistance (exact time will be determined in the directions for use of PU low expansion foam).
7. Cut off the excess of foam with knife, so as to cover it with plaster or gypsum and level to the surface of a wall.
8. Protective foil or tape should be removed from a windowsill when mounting is finished (note: only windowsills with high glossy surface are covered with protective foil).
9. In order to improve the esthetics, junction between the windowsill and window frame/internal lining can be sealed with silicone. Masking strip can also be fastened.

*All materials and agents used should have up-to-date certificates of the Institute of Hygiene and Building Research Institute.

*The installation of the windowsill should be conducted in compliance with good craftsman building practice

LAMINTEX INTERIOR WINDOWSILLS MUST NOT BE EXPOSED TO RAIN OR MOISTURE.